

# PERMISSIBLE HEADLIGHT

501

## DESCRIPTION

CERTIFICATION NUMBER X/P 1650

THE MODEL 501 IS A HEADLIGHT DESIGNED FOR MINING MACHINERY. THE ENCLOSURE HAS BEEN TESTED AND APPROVED UNDER M.S.H.A. SCHEDULE "2-G" 30 CFR PART 18. THIS DUAL GLAND HEADLIGHT IS AVAILABLE IN ALUMINUM (P/N 501-AL) OR BRASS (P/N 501-BR).

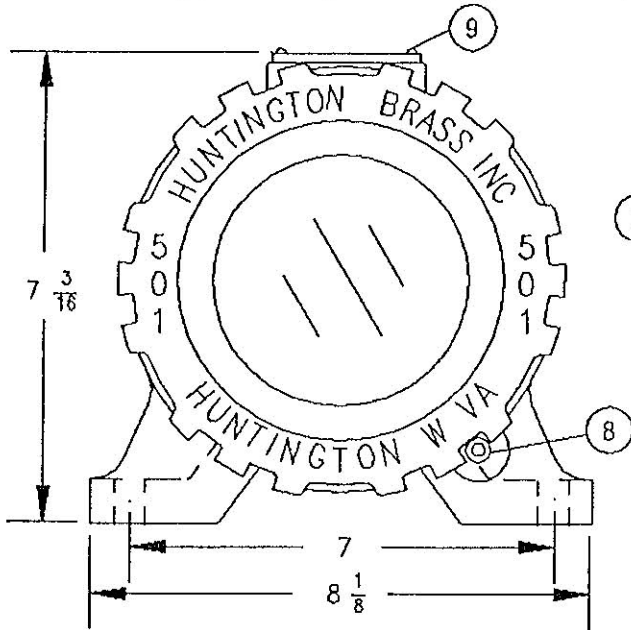

501-LH

B/M FOR 501-AL

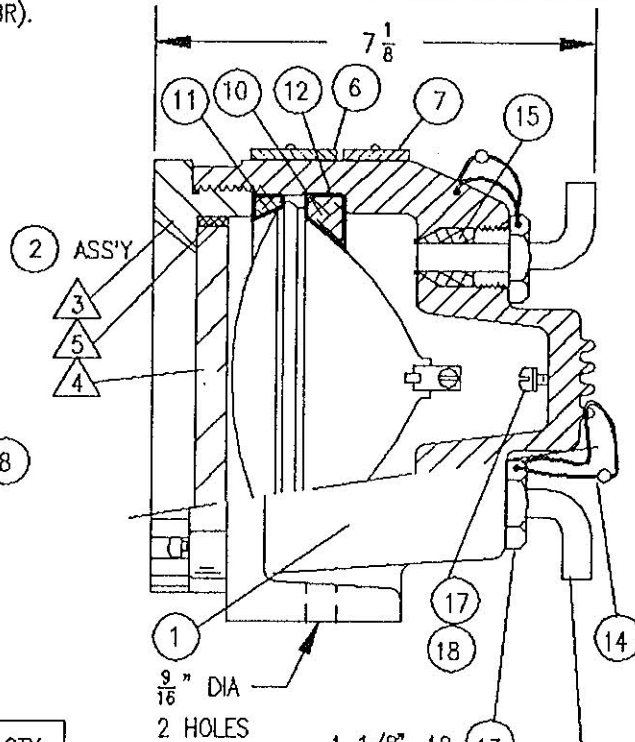

1 1/8" - 12 (13)  
NUTS  
A-24-1 (1/2")  
A-24-2 (5/8")  
A-24-3 (3/4")

STRAIGHT TUBES 90° TUBES (16)  
A-49-1A (1/2") A-49-1B (1/2")  
A-49-2A (5/8") A-49-2B (5/8")  
A-49-3A (3/4") A-49-3B (3/4")

ITEM	DESCRIPTION	PART NUMBER	QTY
1	HOUSING	D-6-AL	1
2	COVER ASSEMBLY	C-5-AL	1
3	COVER	C-1-AL	REF
4	LENS	A-20	REF
5	EPOXY	500	REF
6	I.D. TAG	A-38-2	1
7	PA TAG	A-41-2	1
8	LOCKING SCREW	A-28	1
9	DRIVE SCREW	1000-13	4
10	BULB SEAT	A-19	1
11	BULB SEAT	A-22	1
12	FIBERGLASS TAPE	A-30	6
13	GLAND NUT 1/2"	A-24-1	2
14	WIRE SEAL	A-27	2
15	PACKING	A-29	2
16	STRAIGHT TUBE	A-49-1A	2
17	LOCK WASHER	H107300	1
18	SCREW	H131745	1

### LAMP SPECIFICATIONS:

PAR 46, 60 WATT, 38 VOLT  
 PAR 46, 75 WATT, 48 VOLT  
 PAR 46, 100 WATT, 60 VOLT  
 PAR 46, 150 WATT, 120 VOLT  
 PAR 46, 150 WATT, 175 VOLT